

EMERGING TECH CONFERENCE – Edge Intelligence

Volume 02, 2023, Page 31 – 38

Proceedings of Emerging Tech Conference:
Edge Intelligence 2023

Rapid virtual prototyping of battery storage systems

Sotirios Athanasiou¹ and Georgios Koukos²

¹ Sunlight Group Energy Storage Systems, 14564 Athens, Greece

² Sunlight Group Energy Storage Systems, 67200 Neo Olvio, Greece

s.athanasiou@sunlight.gr, g.koukos@sunlight.gr

Abstract

With this work we present the current approach into virtual prototyping of battery storage systems with MATLAB-Simscape. We show the robustness and effectiveness of the approach as well as the easiness to implement. Multiple components of the battery can be modeled this way and we show that even complicated behavior can be observed. A SOLIDWORKS design provides a more detailed approach to the battery design.

1 Introduction

Studies of battery storage systems in the industry can be roughly divided into 2 categories. Feasibility studies are done for a client, where the designers try to evaluate whether the selected battery cells can fit an application based on rough electrical and mechanical requirements. Virtual prototyping on the other hand can help in evaluating new technologies tested before they reach the actual product development teams. In this work we focus on virtual prototyping where we highlight the basic Battery Module and Battery Management System (BMS) components that are modeled for a specific application. Previously Sunlight Group has worked on Hybrid Storage Systems based on Lead Acid Batteries (LABs) [1,2] and more recently on smaller systems with Lithium-Ion Batteries (LIBs) [3]. Through these works we have identified the importance of simulating battery systems at prototype level and how this can affect sizing and configuration of the battery.

2 Battery storage system technology

2.1. Battery cell models

One of the key aspects in simulating battery storage systems is the battery cell models used. There are 4 major categories for battery cell models: Data driven, Empirical, Equivalent Circuit Models (ECM) and Electrochemical Models [4]. In this case we will be using the default ECM models provided by Simscape:

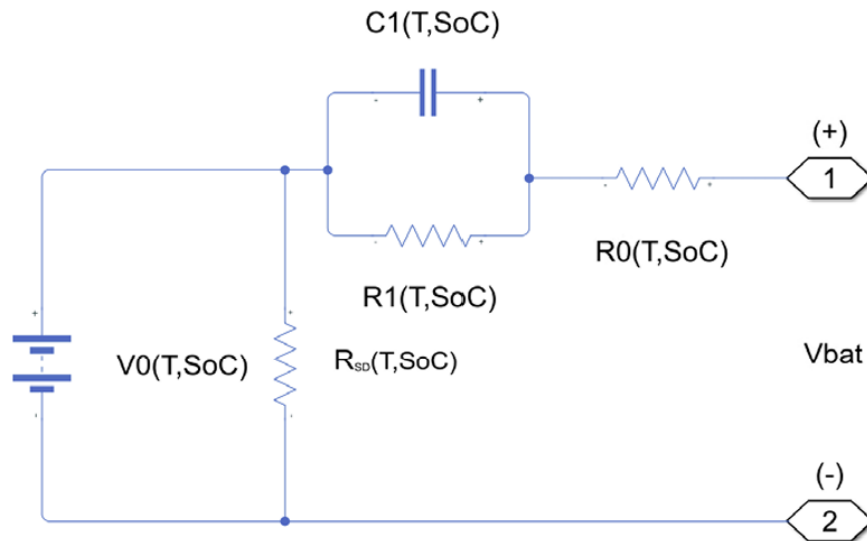

Figure 1: Battery cell ECM used.

Equivalent Circuit Models are models based on electrical elements that are used to emulate behavior of an electrochemical cell. In our case we are modeling the cell dynamic behavior with an RC circuit. Multiple cells are connected in series or in parallel for a battery pack which form the basis the battery. For this work we selected NMC chemistry lithium-ion cells with a capacity of 20Ah. The battery pack configuration selected was the 1P4S configuration.

2.2. Battery Management System

The battery management system is one of the key components of a Lithium-Ion battery. It is responsible for ensuring the safety of the battery, as well as calculating various parameters; for example, State of Charge (SOC) and State of Health (SOH). Regarding the safety of the battery storage system, the BMS is reacting towards opening the switching elements (effectively cutting-off power) in case a set of safety conditions is violated.

2.3. Battery charger / load

The energy storage system is connected to either a load or a charger at any given time. In some cases, it can be connected on both, but the battery can be either on Charging or Discharging state. Charging algorithms can be divided in different categories depending on the conditions used to charge the battery; Constant current constant voltage (CC-CV) charges the battery with a constant current, while afterwards the charger maintains a constant voltage. Constant power constant voltage (CP-CV) charges the battery with a constant power, while afterwards the charger maintains a constant voltage. In our case we will be using a CC-CV charger algorithm to charge the battery.

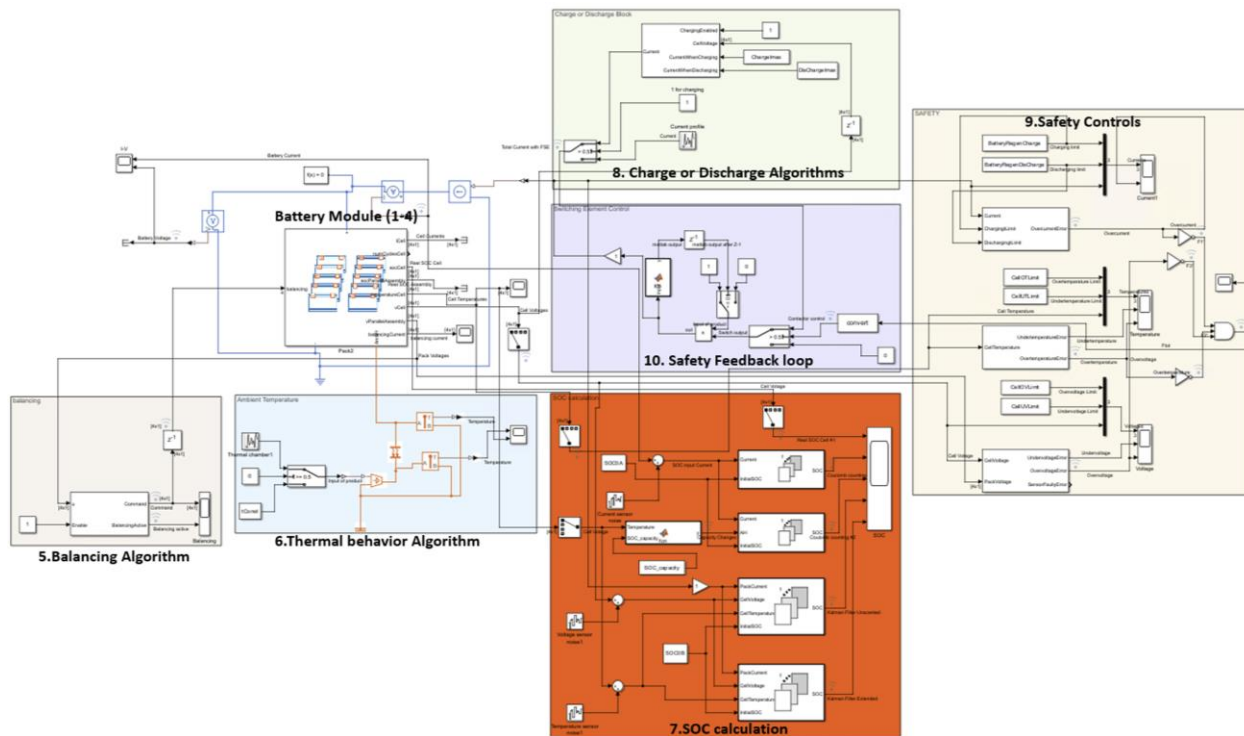

Figure 2: Battery testbench global view

3 Implementation

Battery parametrization is done through specific MATLAB-Simscape blocks and custom MATLAB functions. We parameterize cell dimensions and electrical connectivity of the battery pack. This virtual battery is then customized through initializing the components of the cells' ECM. Specific functionality was implemented to randomize the cell's status and force the energy balancing behavior. Figure 2 presents the experimental setup of the battery, with all its behavior modeled. All parameters were adjusted from parameters used in actual products to create a more accurate behavior. In figure 3 below we can see the methodology followed to create the battery model and its testbench. We will be briefly presenting the options of most of these blocks in the following paragraph and then we will be focusing on the safety control and safety feedback loop.

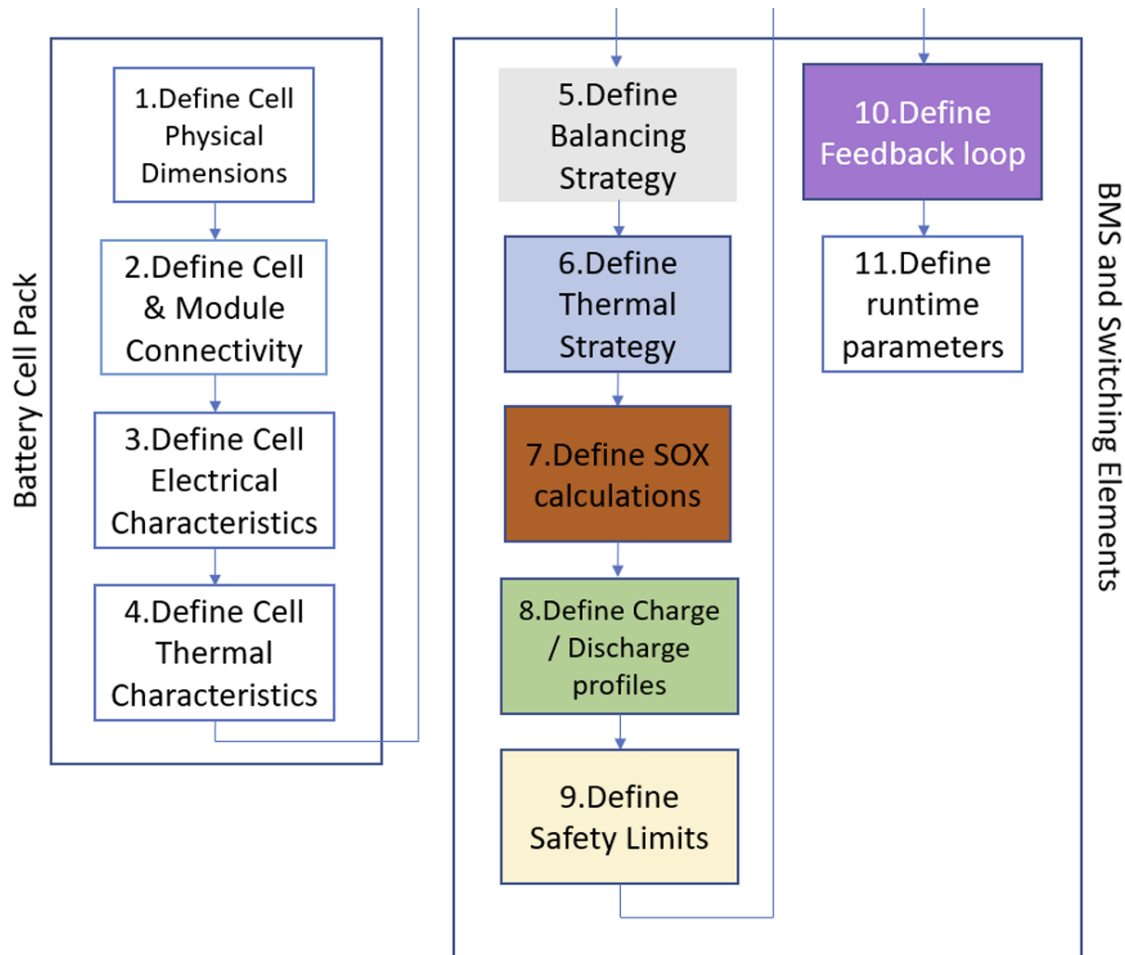

Figure 3: Methodology flowchart

3.1. Main setup

Generally, to define the battery pack you need to base your model on actual battery cell parameters. By using a cell datasheet, the mechanical (Figure 5) and some of the electrical characteristics can be defined (steps 1-4). For the missing parameters, cell characterization must be performed to obtain them. Alternatively, for parameters with a reduced impact on the results, simplified assumptions can be made. For the balancing strategy (step 5) we chose passive balancing with typical balancing threshold values. For the thermal strategy (step 6) we are assuming a constant environmental temperature that affects our cells through convective heat transfer. For the SOC subsystem (step 7) we compared the following algorithms:

1. Coulomb counting
2. Coulomb counting with variable capacity
3. Unscented Kalman filter
4. Extended Kalman filter

We can clearly see in Figure 4 the difference in calculated SOC values depending on the method used.

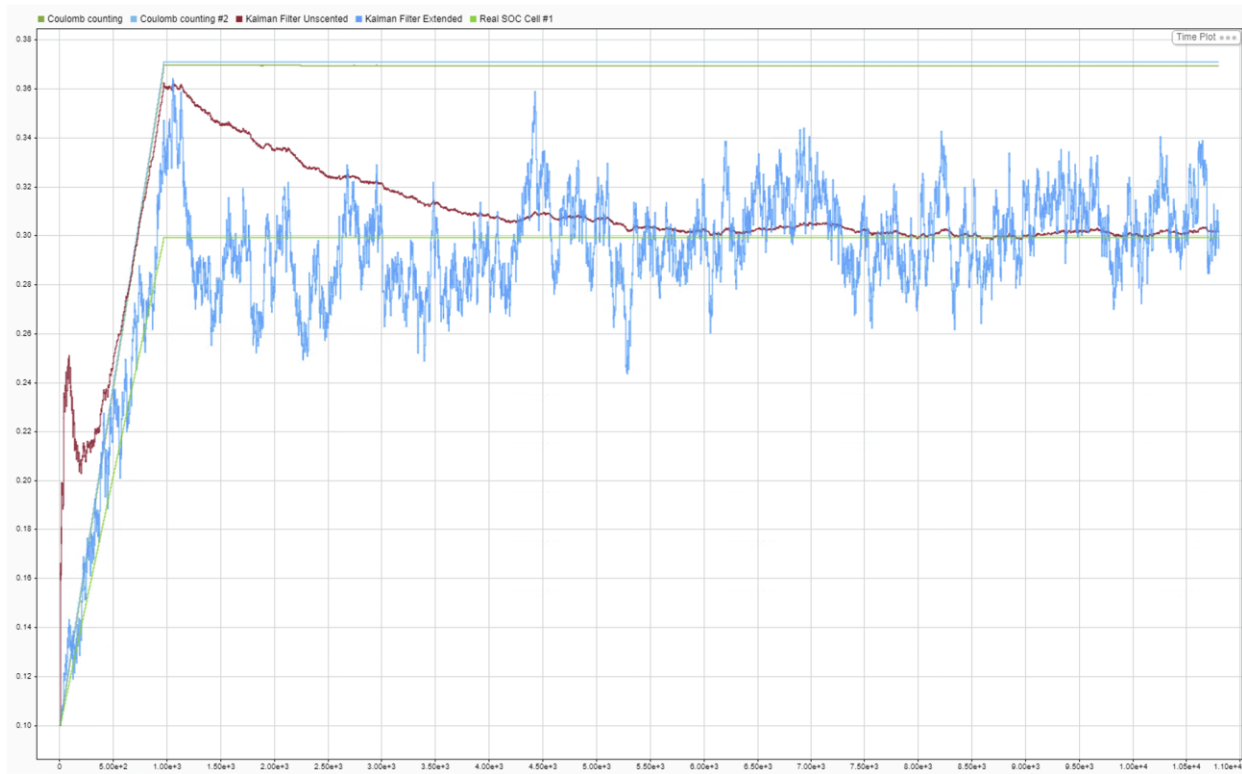

Figure 4: Comparison of different SOC calculation methodologies

Furthermore, in the case of charge and discharge algorithms (step 8) we applied a CC-CV charge algorithm with the maximum charge voltage extrapolated from the maximum voltage defined by the cell datasheet.

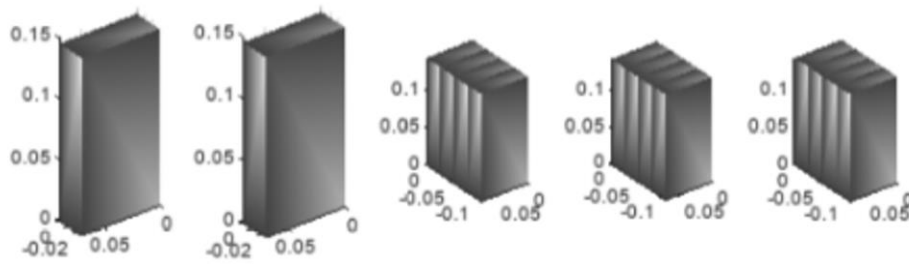

Figure 5: Battery pack physical modeling

3.2. Safety

One of the key aspects of a battery is its safety of Li-ion batteries [6]. To this end most of battery products need to comply with very strict regulations regarding functional safety [7]. In Figure 6 we demonstrate the way functional safety is implemented in Simscape. 3 different blocks simulate different BMS functions: Overcurrent protection, over/under voltage protection and over/under temperature protection are implemented. The system generates an error in case any of these limits are violated, which in turn opens a switching element. This action cutoffs completely the current flow in or out of the battery, thus leading the battery to a safe state.

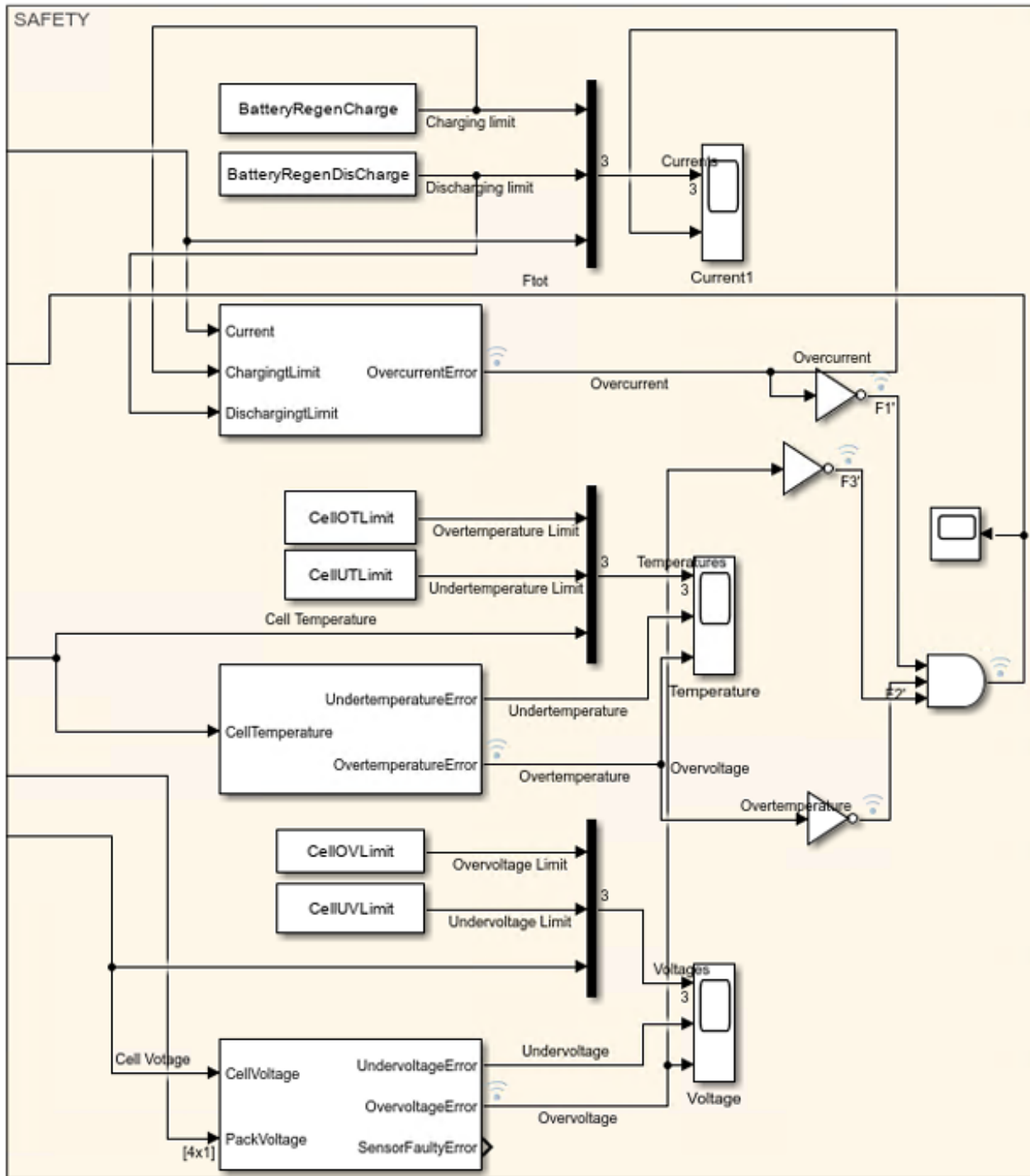

Figure 6: Safety Implementation of a Li-Ion battery

4 Results

We present below the results of temperature monitoring. As the temperature exceeds the overtemperature limit, we open the switching elements and temperature decreases to the initial value. The effect is seen on the current behavior where a drop is observed due to the open circuit.

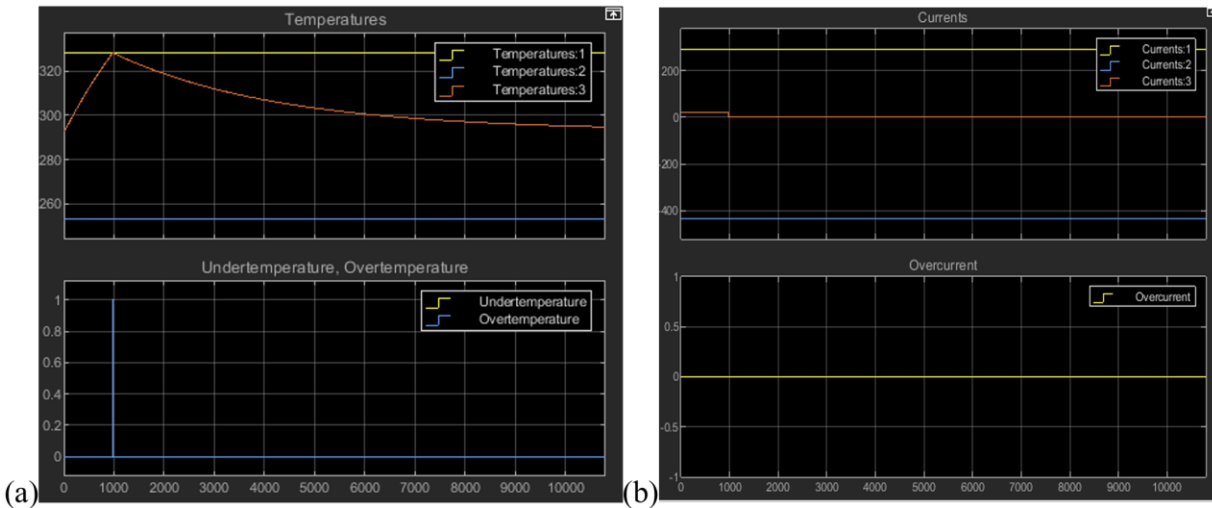

Figure 7: (a)Temperature monitoring and over/under temperature safety limits. (b) Current limit monitoring

This kind of behavior can be observed for all the battery subsystems, including voltage monitoring and charging. We use this methodology to size a battery for a specific application. The step that follows is creating in a CAD software the battery itself. Below we show the SOLIDWORKS drawing of the battery. In 3 different configurations. We see observe the electronic components on top of the Printed Circuit Board (PCB) as well as the cell configuration and the busbars.

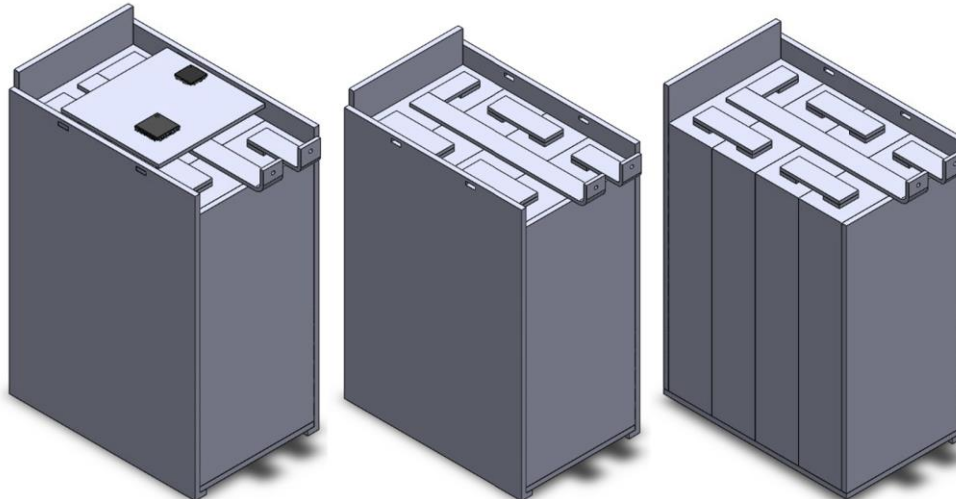

Figure 8: SOLIDWORKS design of the Lithium Ion Battery

5 Conclusions

With this work we presented a rapid prototyping approach. We use MATLAB-Simscape to insert the physical and electrical model of the cells in a specific configuration to form the battery module. We model the rest of the battery configuration by modeling the BMS functions as well as the battery charger behavior. By simulating the whole system, we can extract its behavior and use it to carefully size the battery components. We present the final step of this process by designing the key aspects of the battery with CAD software.

6 Acknowledgements

This project was partially funded by SHB (Smart Healthy Batteries) project from Eastern Macedonia & Thrace region as well as IPCEI EuBatIn project. We would like to thank MathWorks for their support during this work. We thank multiple Sunlight Group colleagues for providing various information for these simulations.

7 References

- [1] Chrysovalantou Ziogou, Dimitris Ipsakis, Costas Elmasides, Fotis Stergiopoulos, Simira Papadopoulou, Panos Seferlis, Spyros Voutetakis, Automation infrastructure and operation control strategy in a stand-alone power system based on renewable energy sources. *Journal of Power Sources* Volume 196, Issue 22, 15 November 2011, Pages 9488-9499
- [2] Damian Giaouris, Athanasios I. Papadopoulos, Chrysovalantou Ziogou, Dimitris Ipsakis, Spyros Voutetakis, Simira Papadopoulou, Panos Seferlis, Fotis Stergiopoulos, Costas Elmasides, Performance investigation of a hybrid renewable power generation and storage system using systemic power management models, *Energy* 61 (2013) 621e635
- [3] Asimina Dimara, Christos Sougles, Sotirios Athanasiou, Konstantinos Grigoropoulos, Panagiota Sfakianou, Alexios Papaioannou, Stelios Krinidis, Dimitrios Triantafyllidis, Ioannis Tzitzios, Christos Nikolaos Anagnostopoulos, Aristoklis Karamanidis, Vaia Saltagianni, Dimosthenis Ioannidis, Dimitrios Tzovaras, Holistic plug-n-play autonomous solar system integration: a real-life small-scale demonstration—a practical approach, *Electrical Engineering* (2023)
- [4] Hegazy Rezk, A. G. Olabi, Tabbi Wilberforce, Enas Taha Sayed, A Comprehensive Review and Application of Metaheuristics in Solving the Optimal Parameter Identification Problems, *Sustainability* 2023.
- [5] Min Chen, Gabriel A. Rincon-Mora, Accurate Electrical Battery Model Capable of Predicting Runtime and I–V Performance
- [6] Languang Lu, Xuebing Han, Jianqiu Li, Jianfeng Hua, Minggao Ouyang, A review on the key issues for lithium-ion battery management in electric vehicles
- [7] UL, <https://www.ul.com/services/functional-safety>